



CHI LIN TECHNOLOGY CO., LTD.

Product Specifications

Customer	
Description	8.4 " TFT LCD Module
Model Name	LR084AA012
Date	2007.03.26
Doc. No.	
Revision	A

Customer Approval	
Date	
The above signature represents that the product specifications, testing regulation, and warranty in the specifications are accepted	

Engineering			
Check	Date	Prepared	Date

Head Office & Factory : No. 71, Te Lun Rd., Jen Te Hsiang, Tainan County 717, Taiwan, R.O.C.
 Tel : +886-6-279-4113
 Fax: +886-6-279-1194

Preliminary

1. Summary

This module utilizes amorphous silicon thin film transistors and a 16:9 aspect ratio. A 8.4" active matrix liquid crystal display allows full color to be displayed.

The applications are Portable DVD. Multimedia applications and others AV system.

2. Features

- Utilizes a panel with a 16:9 aspect ratio, which makes the module suitable for use in wide-screen systems.
- The 8.4" screen produces a high resolution image that is composed of 112.320 pixel elements in a stripe arrangement. By adopting an active matrix drive, a picture with high contrast is realized.
- A thin, light and compact module is accomplished through the use of COG mounting technology.

3 . General Specification

CHARACTERISTIC ITEM	SPECIFICATION
Video Signal Interface	Analog Video Interface
Display Technology	a-Si TFT active matrix
Display Mode	TN Type Full Color / Transmitting Type / Normally White
Screen Size (Diagonal)	8.4"
Outline Dimension	199.5mm(W) X 118.9mm(H) X 7.3mm(D)
Active Area	185.76mm(W) X 104.6mm(H)
Number Of dots	480(W) X 3(RGB) X 234(H)
Dot Pitch	0.129mm(W) X 0.447mm(H)
Color Filter Array	RGB vertical stripes
Weight	258 g (TYP)
Backlight	CCFL with 3 wave-length spectrum (L Type)
Surface Treatment	Anti-Glare Treatment

Preliminary

4. Interface (Input Terminal)

4.1. TFT-LCD Panel Driving Part

Pin No.	SYMBOL	I/O	FUNCTION	REMARK
1	GND	-	Ground for logic circuit	
2	VCC	I	Supply voltage for logic control circuit	
3	VGL	I	Negative power for scan driver	
4	VGH	I	Positive power for scan driver	
5	STVR	I/O	Vertical start pulse	
6	STVL	I/O	Vertical start pulse	
7	CKV	I	Shift clock input for scan driver	
8	U/D	I	UP/DOWN scan control input	
9	OEV	I	Output enable input for scan driver	
10	VCOM	I	Common electrode driving signal	
11	VCOM	I	Common electrode driving signal	
12	L/R	I	LEFT/RIGHT scan control input	
13	MOD	I	Analog signal rotate input	
14	OEH	I	Output enable input for data driver	
15	STHL	I/O	Start pulse for horizontal scan line	
16	STHR	I/O	Start pulse for horizontal scan line	
17	CPH3	I	Sampling and shifting clock pulse for data driver	
18	CPH2	I	Sampling and shifting clock pulse for data driver	
19	CHP1	I	Sampling and shifting clock pulse for data driver	
20	VCC	I	Supply voltage of logic control circuit	
21	GND	-	Ground for logic circuit	
22	VR	I	Alternated video signal input (Red)	
23	VG	I	Alternated video signal input (Green)	
24	VB	I	Alternated video signal input (Blue)	
25	AVDD	I	Supply voltage for analog circuit	
26	AVSS	-	Ground for analog circuit	

Preliminary

4.2. Backlight Fluorescent Tube Driving Part

Pin No.	SYMBOL	FUNCTION	REMARK
1	HI	Power supply for backlight unit (high voltage)	
2	GND	Ground for backlight unit	

5. Absolute Maximum Ratings

Item	Symbol	Condition	Min.	Max.	Unit	Remark
Power voltage	VCC	GND=0	-0.3	7	V	
	AVDD	AVSS=0	-0.3	7	V	
	VGH	GND=0	-0.3	18	V	
	VGL		-15	0.3	V	
	VGH-VGL		-	33	V	
Input signal voltage	Vi		-0.2	$AV_{DD}+0.2$	V	Note 1
	VI		-0.3	$V_{CC}+0.3$	V	Note 2
	VCOM		-2.9	5.2	V	
Operating Temperature	Top		-10	60	°C	Ambient temperature
Storage Temperature	Tstg		-20	70	°C	Ambient temperature

Note 1 : VR, VG, VB

Note 2 : STHL, STHR, Q1H, OEH, L/R, CPH1-CPH3, STVR, STVL, OEV,CKV,U/D

Preliminary

6. Electrical Characteristics

6.1. Recommended Operating Conditions

6.1.1 TFT-LCD Panel Driving Section

Item	Symbol	Min.	Typ.	Max.	Unit	Remark	
Power supply	VCC	4.8	5	5.2	V		
	AVDD	4.8	5	5.2	V		
	VGH	14.3	-	15.7	V		
	VGL	-10.5	-10	-9.5	V		
Video signal amplitude (VR, VG, VB)	ViA	0.2	-	AVDD-0.2	V		
	ViAC	-	3.0	3.8	V	AC component	
	ViDC	-	AVDD/2	-	V	DC component	
VCOM	VCAC	3.5	4.8	6.1	V	AC component Note 2	
	VCDC	1.7	2	2.3	V	DC component	
Input Signal voltage	H Level	VIH	$0.8V_{CC}$	-	V_{CC}	V	Note 3
	L Level	VIL	0	-	$0.2V_{CC}$		
Current for driver	VGH=15V	IGH	-	0.2	0.5	mA	
	VGL=-10V	IGL	-	0.8	1.5	mA	
	VCC=5V	ICC	2.7	3.3	5.5	mA	
	AVDD=5V	IDD	-	17	30	mA	

Note 1 : The same phase and amplitude with common electrode driving signal (VCOM).

Note 2 : The brightness of LCD panel could be changed adjusting the AC component of VCOM.

Note 3 : STHL, STHR, Q1H, OEH, L/R, CPH1~CPH3, STVR, STVL, OEV, CKV, U/D.

Note 4 : Be sure to apply GND, VCC and VGL (VGL must lower then 0 volt) to the LCD first, and then apply VGH.

Preliminary

6.1.2 Backlight Driving Section

Parameter	Symbol	Min.	Typ.	Max.	Unit	Remark
Lamp voltage	VL	-	637	-	Vms	Note 1
Lamp current	IL		6	-	mAms	Note 1
Power consumption	PL	-	3.8	-	W	Note 2
Lamp starting voltage	VS	-	-	-	Vms	T=0°C
		1050	-	-		T=25°C
Frequency	FL	45	-	60	KHZ	Note 3
Lamp life time	LL	10,000	15,000	-	Hr	Note 1,4

Note 1 : T=25°C, IL=6.0mA

Note 2 : Inverter should be designed with the characteristic of lamp. When you are designing the inverter, the output voltage of the inverter should comply with the following conditions.

(1). The area under the positive and negative cycles of the waveform of the lamp current and lamp voltage should be area symmetric (the symmetric ratio should be larger than 90%).

(2) There should not be any spikes in the waveform.

(3) The waveform should be sine wave as possible.

(4) Lamp current should not exceed the maximum value within the operating Temperature (It is prohibited to over the maximum lamp current even if operated in the non-guaranteed temperature). When lamp current over the maximum value for a long time, it may cause fire. Therefore, it is recommend hat the inverter should have the current limited circuit.

Note 3 : Lamp frequency may produce interference with horizontal synchronous frequency and this may cause line flow on the display. Therefore lamp frequency shall be detached from the horizontal synchronous frequency and its harmonics as far as possible in order to avoid interference.

Note 4 : Brightness (IL=6.0mA) to be decrease to the 50% of the initial value.

Note 5 : CN2 connector (backlight) : JST BHSR-02VS-1
 Mating connector : JST SM02B-BHSS-1-TB

Preliminary

6.2. Timing Characteristics of input signals

	Parameter	Symbol	Min.	Typ.	Max.	Unit	Conditions	
Source	Clock cycle time	Tcph	45	-	2000	ns	CPHn	
	CPHn pulse duty	Tcwh	40	-	60	%	CPHn	
	CPHn phase delay	Tc12	12		-	Tcph/2	ns	CPH1~CPH2
		Tc23			-			CPH2~CPH3
		Tc31			-			CPH3~CPH1
	Set-up time of analog signals	Tasu	16	-	-	ns	VA,VB,VC-CPHn	
	Hold time of analog signals	Tahd	16	-	-	ns	CPHn-VA,VB,VC	
	STHn set-up time	Tsu	16	-	-	ns	STHn-CPHn	
	STHn hold time	Thd	16	-	-	ns	CPHn-STHn	
	Propagation delay of STHn	Tphl	16	24	27	ns	CL=25pF	
	Sample and hold disable time	Tdis	1	-	-	us	OE-STHn	
	OE pulse width	Ttwoe	1	-	-	Tcph		
	Setting time	Tst	-	12	20	us	90% final value,CL=60pF	
	AC Characteristics (VCC=2.5~5.5V , AVDD=5V , TA=25°C)							
Gate	STVD/STVU Delay Time	Tdt	-	-	500	ns	CL=20pF	
	Driver Output Delay Time	Tdo	-	-	900	ns	CL=220pF	
	Output Falling Time	Tthl	-	400	800	ns	CL=220pF,90% to 10%	
	Output Rise Time	Ttlh	-	500	1000	ns	CL=220pF,10% to 90%	
	XON to Driver Output Delay Time	Txon	-	-	10	us	CL=220pF	
	OEx to Driver Output Delay Time	Toe	-	-	900	ns	CL=220pF	
	Clock Frequency	Fclk	-	-	200	KHz	In cascade connection	
	Clock Rise Time	Trck	-	-	100	ns	CL=20pF	
	Clock Falling Time	Tfck	-	-	100	ns	CL=20pF	
	Clock Pulse Width(High & Low)	PWCLK	500	-	-	ns		
	STVD/STVU Set-up Time	Tsu	200	-	-	ns		
	STVD/STVU Hold Time	Thd	300	-	-	ns		
	Output Enabled pulse width	Twcl	1	-	-	us		
	AC Characteristics(VGG=25V , VEE=-15V , VCC=3.3V , GND=0V , TA=25°C)							

Preliminary

6.3 Signal For Reverse Scanning

Setting of scan control input		IN/OUT state For start pulse				Scanning direction
U_D	R/L	STVD	STVU	STH1	STH2	
GND	VCC	OUT	IN	IN	OUT	From up to down, from left to right.
VCC	GND	IN	OUT	OUT	IN	From down to up, from right to left.
GND	GND	OUT	IN	OUT	IN	From up to down, from right to left.
VCC	VCC	IN	OUT	IN	OUT	From down to up, from left to right.

* * * H(High Level)=VCC / L (Low Level) = GND

* Definition of scanning direction:

*

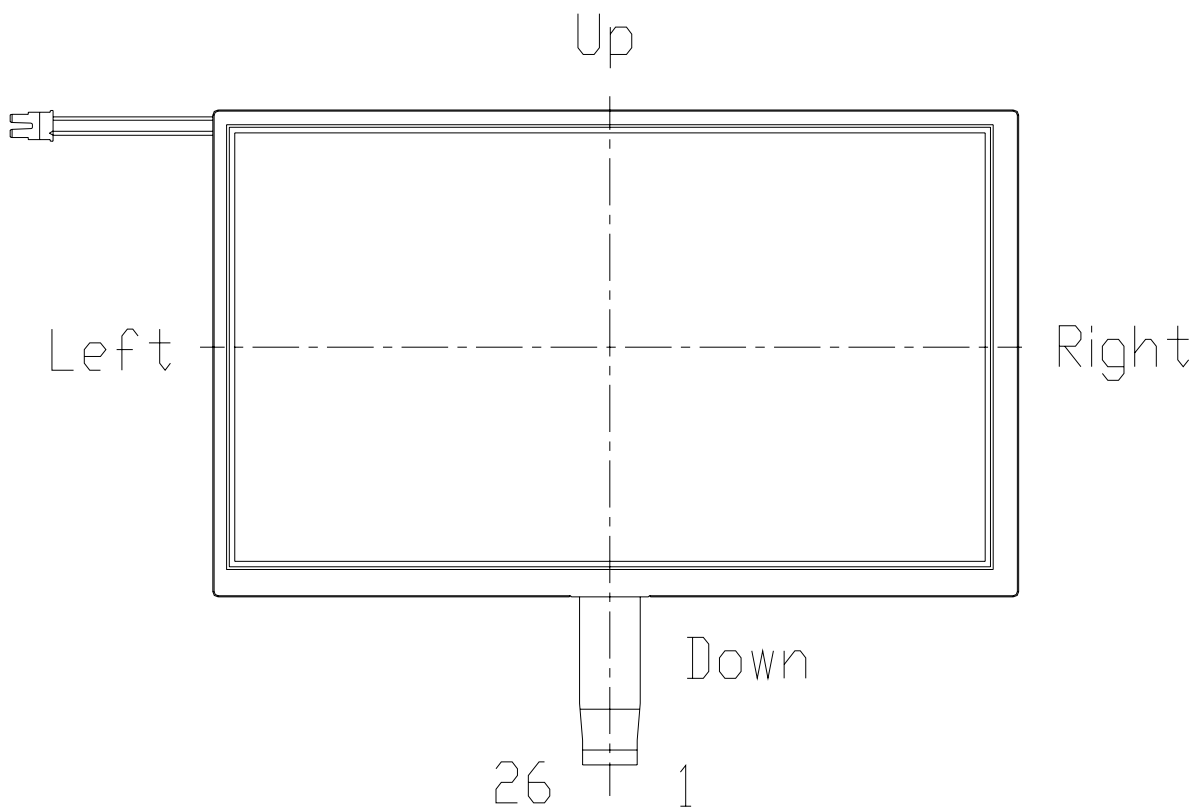

Preliminary

6.4. Sampling Mode Change

SEQ/SIM	H (High Level)	L (Low Level)
MOD	Simultaneous Sampling Mode	Sequential Sampling Mode

■ Timing Diagram

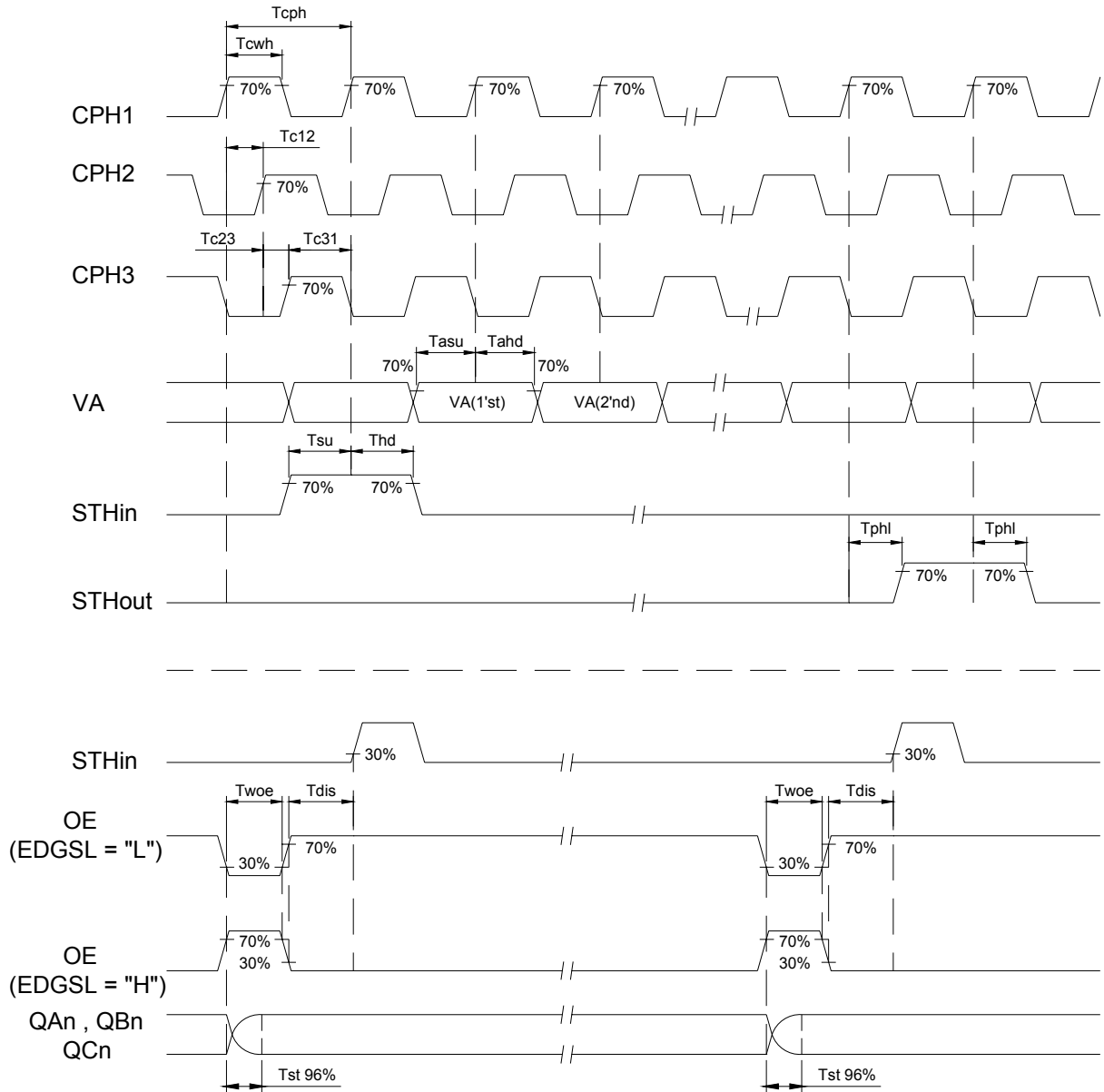

Preliminary

■ Function Operation Timing Diagram

(1) MOD="L", R/L="H"

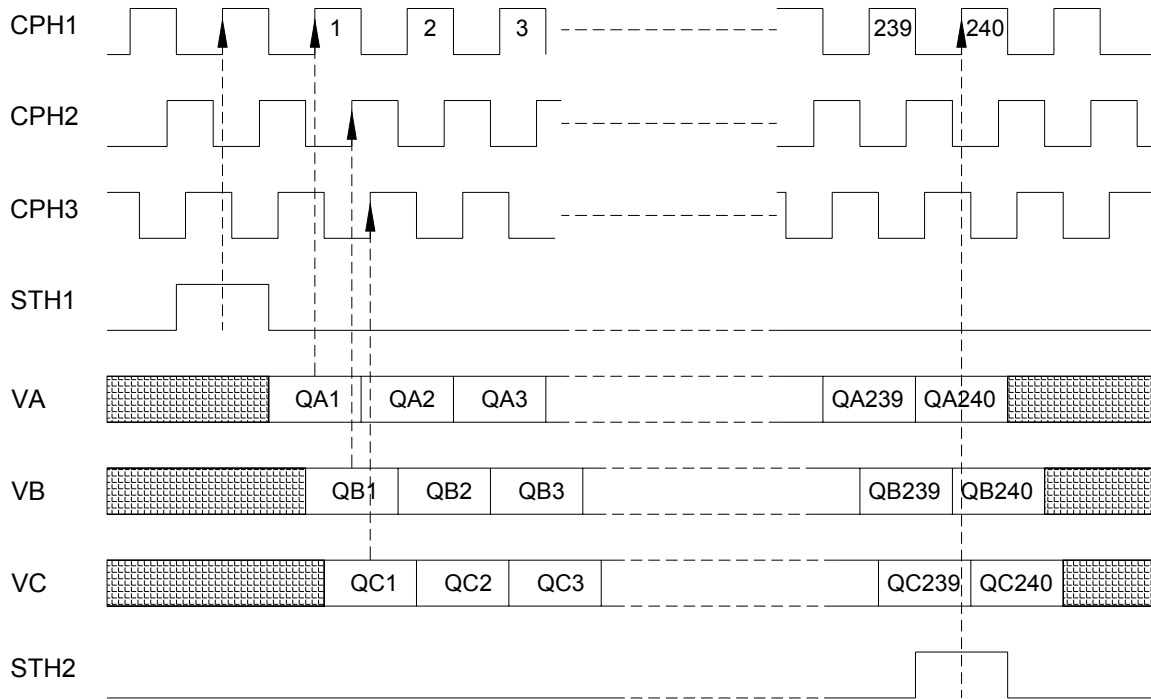

Preliminary

(2)MOD="L",R/L="L"

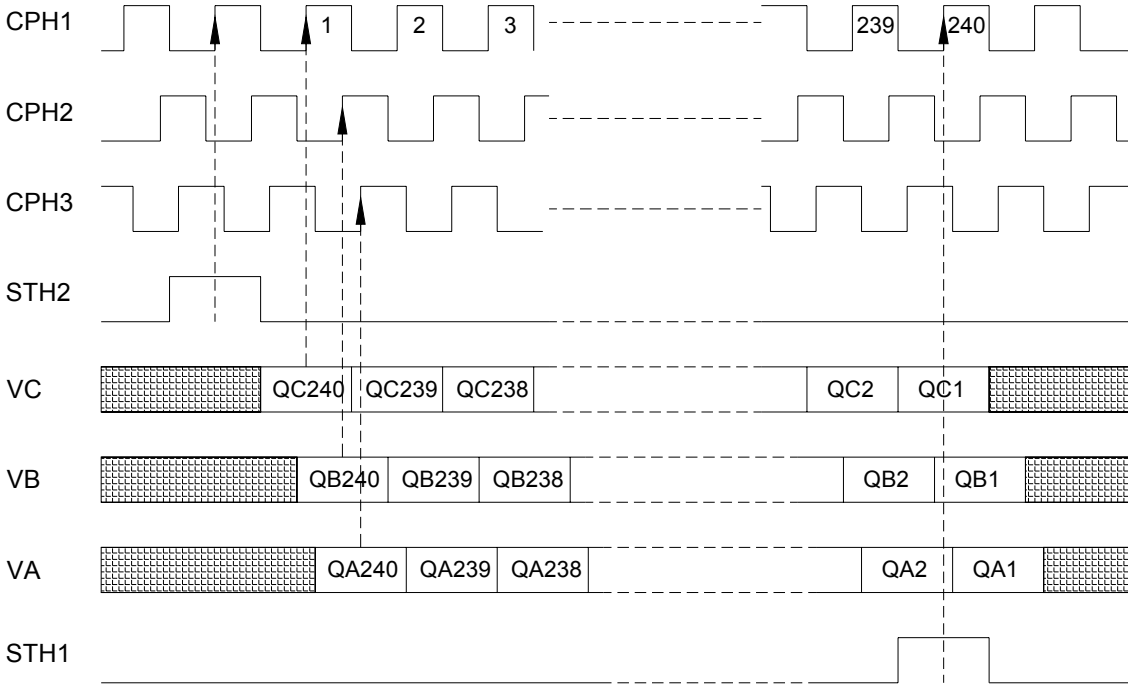

(3)MOD="H",R/L="H"

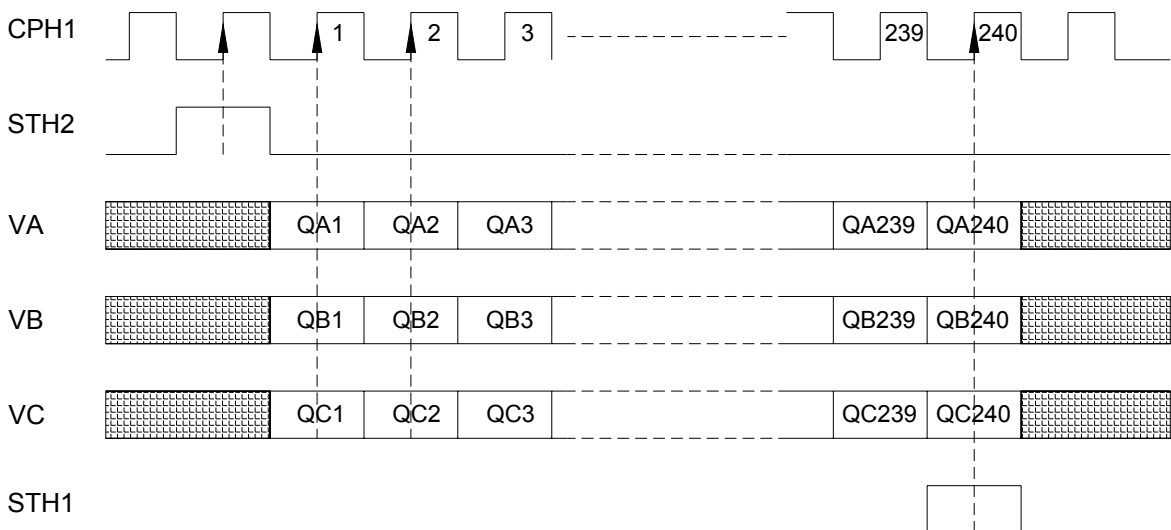

Preliminary

(4)MOD="H",R/L="L"

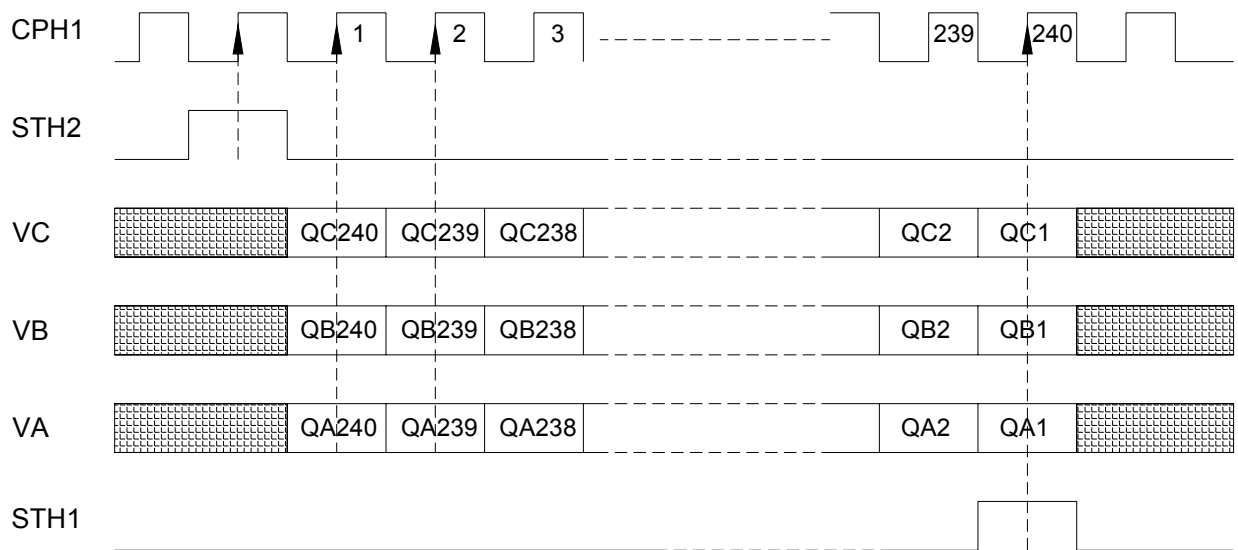

Preliminary

■ Operation(Single-pulse)

1.U_D = "H"

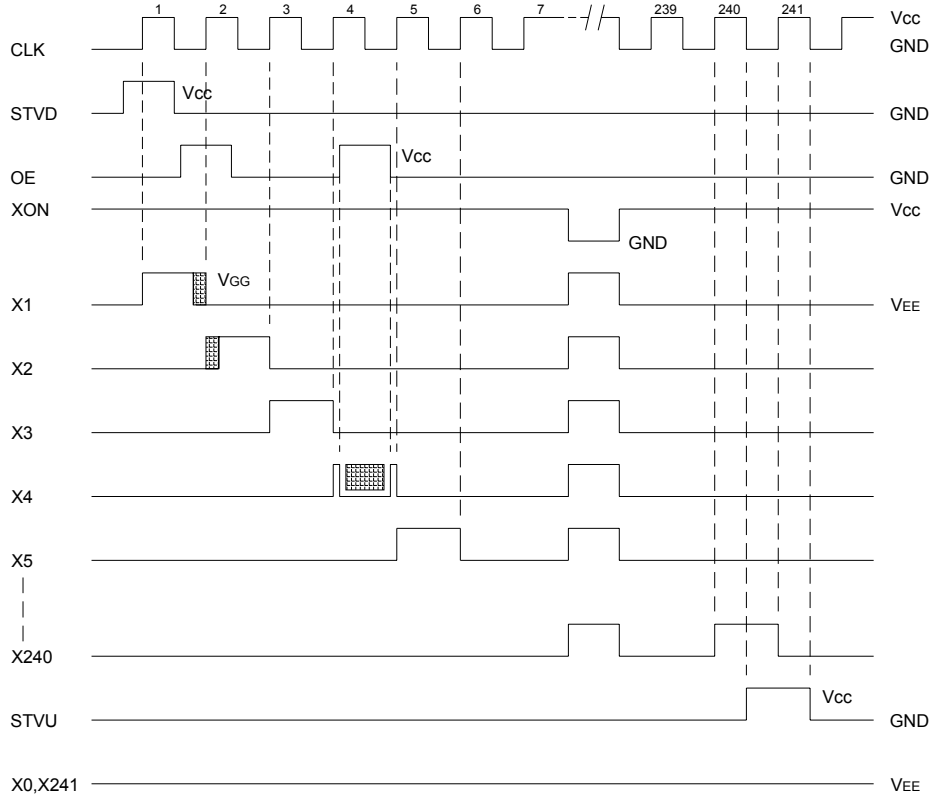

2.U_D = "L"

 : Deleted from normal output by OE

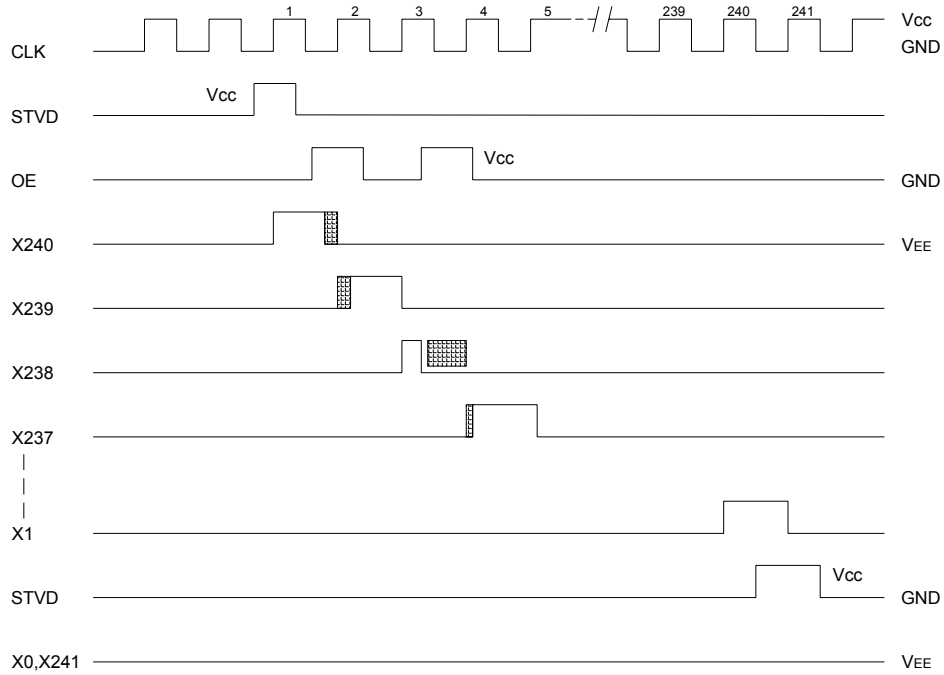

Preliminary

■ Operation(Double-pulse)

1.U_D = "H"

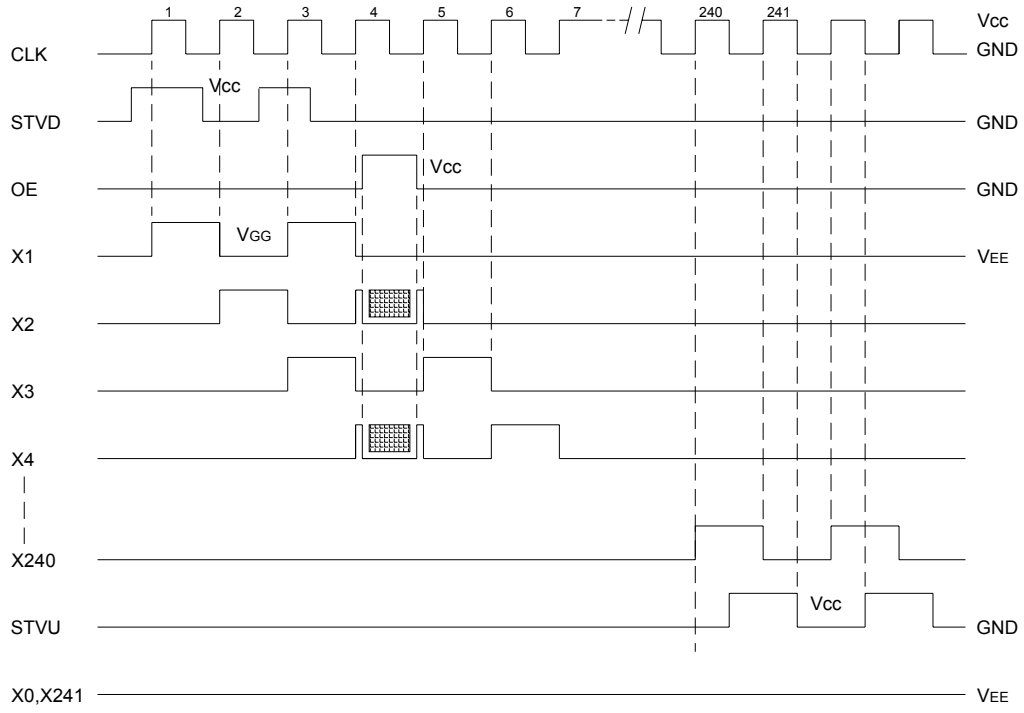

2.U_D = "L"

 : Deleted from normal output by OE

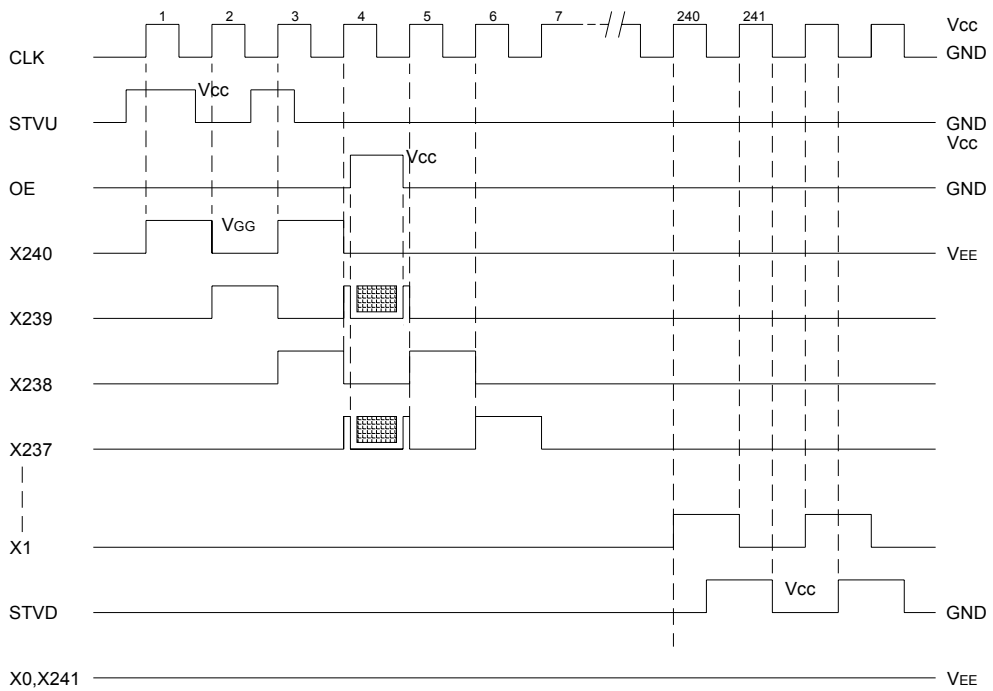

Preliminary

■ Power on/off sequence:

This IC is a high-voltage LCD driver, so it may be damaged by a large current flow if an incorrect power sequence is used. Connecting the drive powers, VEE & VGG, after the logical power, VCC, is the recommended sequence. When shutting off the power, shut off the drive power and then the logic system or turn off all power simultaneously.

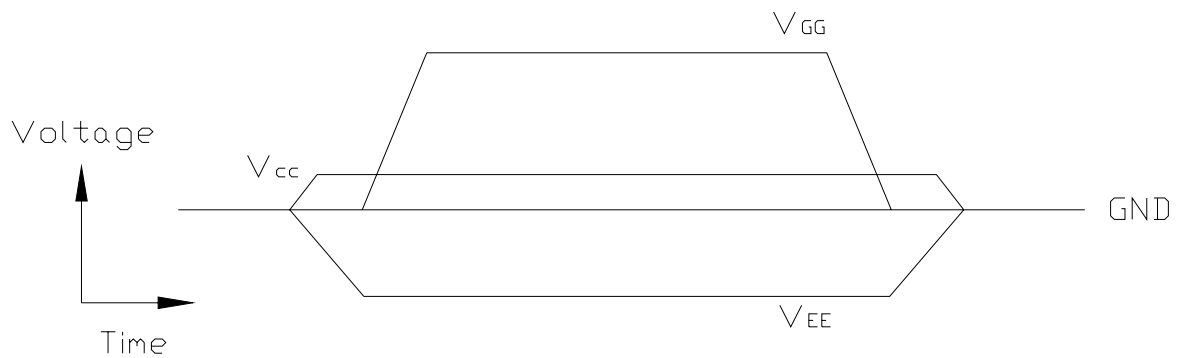

Preliminary

7. Electro-optical Characteristics

PARAMETER	SYMBOL	CONDITION	MIN.	TYP.	MAX.	UNIT	REMARK
Luminance	Y	$I_{BL}=6mArms$	-	300	-	cd/m ²	【Note7-1】
Contrast Ratio	CR	Optimal	-	350	-	-	【Note7-2】
White color Chromaticity	W_x	$I_{BL}=6mArms$	0.26	0.31	0.36	-	【Note7-1】
	W_y		0.28	0.33	0.38	-	
Viewing Angle	$\psi=180^\circ$	$CR \geq 10$	θ_l	-	70	-	【Note7-2】
	$\psi=0^\circ$		θ_r	-	70	-	
	$\psi=90^\circ$		θ_u	-	50	-	【Note7-3】
	$\psi=270^\circ$		θ_d	-	65	-	-
Response time	Rise	$\theta=0^\circ$	t_r	-	15	30	【Note7-4】
	Fall		t_d	-	25	50	

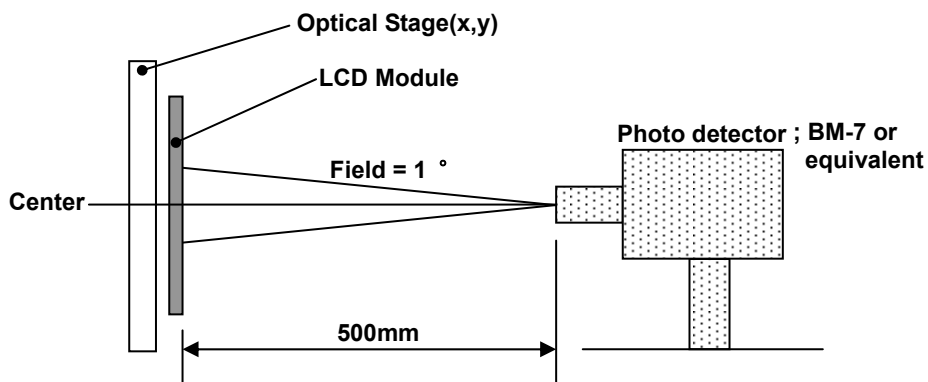

Measuring Condition :

- Measuring surroundings : Dark Room
- Measuring temperature : $T_a=25^\circ C$
- Adjust operating voltage to get optimum contrast at the center of the display.
- Measured value at the center point of LCD panel after more then 30 minutes while backlight turning on.

Preliminary

【Note 7-1】

Measured on the center area of the panel by TOPCON photometer BM-7 or equivalent.

【Note 7-2】

Contrast ratio is defined as follows :

$$\text{Contrast Ratio(CR)} = \frac{\text{Photo detector output with LCD being "white"}}{\text{Photo detector output with LCD being "black"}}$$

【Note 7-3】

Viewing angle range is defined as follows :

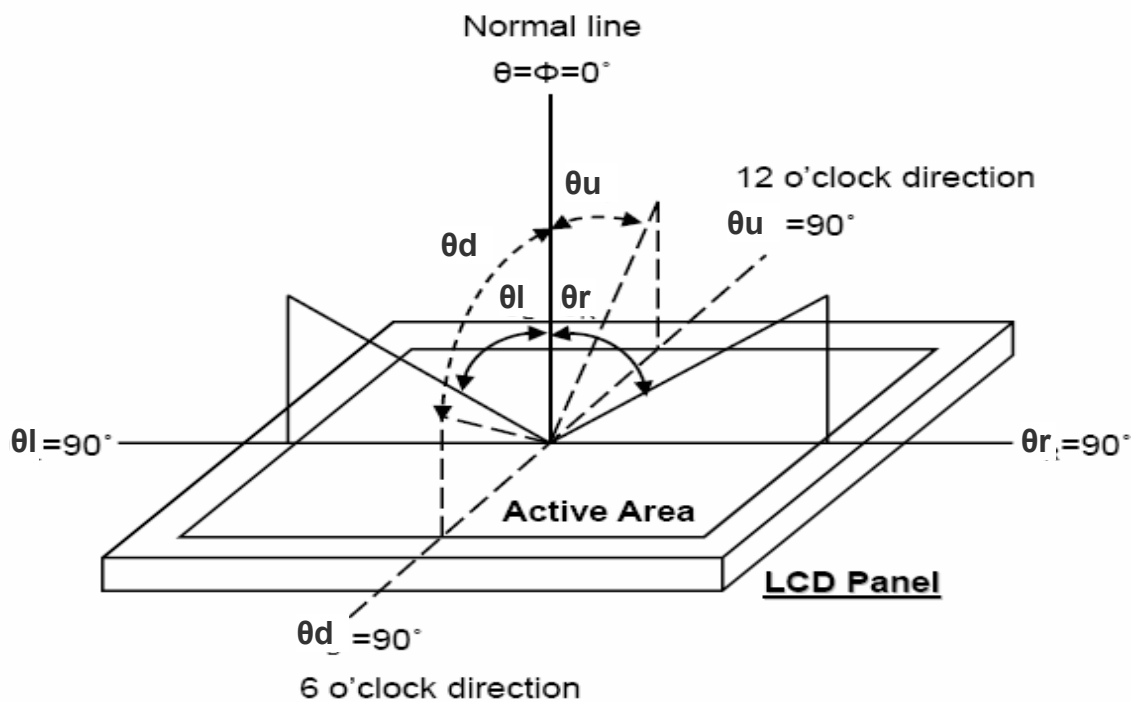

Preliminary

【Note 7-4】

Response time is obtained by measuring the transition time of photo detector output, when input signals are applied so as to make the area "black" to and from "white".

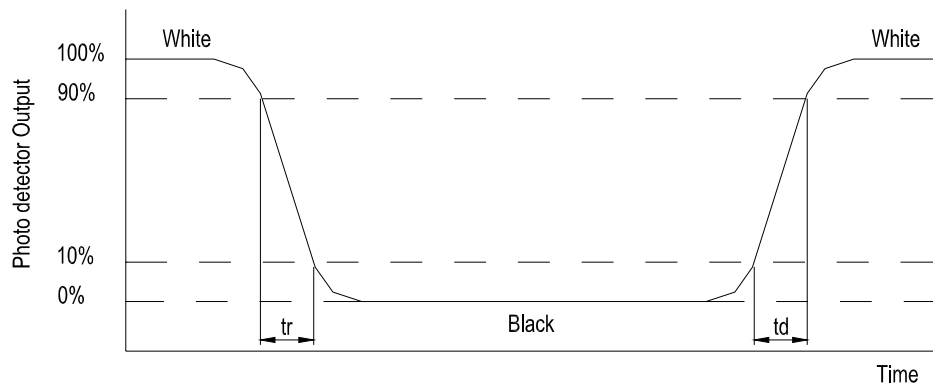

8. Mechanical Characteristics

PARAMETER	SPECIFICATION		UNIT	REMARK
Outline Dimension	Width	199.5	mm	
	Height	118.9	mm	
	Depth	7.3(TYP)	mm	
Bezel Area	Width	189.8	mm	
	Height	108.6	mm	
Active Display Area	Width	185.76	mm	
	Height	104.6	mm	
Weight	258 (TYP.)		g	
Surface Treatment	Anti-Glare Treatment		-	

Preliminary

9. Quality Assurance

No.	Test Items	Test Condition	REMARK
1	High Temperature Storage Test	Ta=70°C 240h	
2	Low Temperature Storage Test	Ta=-20°C 240h	
3	High Temperature Operation Test	Ta=60°C 240h	
4	Low Temperature Operation Test	Ta=-10°C 240h	
5	High Temperature and High Humidity Operation Test	Ta=60°C 90%RH 240h	
6	Electro Static Discharge Test	-Panel Surface/Top_Case: 150pF ±15kV 150Ω (direct discharge, five times) -FPC input terminal : 100pF ±200V 0Ω	
7	Shock Test (non-operating)	Half sine wave, 180G, 2ms one shock of each six faces (I.e. run 180G 2ms for all six faces)	
8	Vibration Test (non-operating)	Sine wave, 10 ~ 500 ~ 10Hz, 1.5G, 0.37oct/min 3 axis, 1hour/axis	
9	Thermal Shock Test	-20°C(0.5h) ~ 70°C(0.5h) / 100 cycles	

***** Ta= Ambient Temperature

Preliminary

10. Outline Dimension

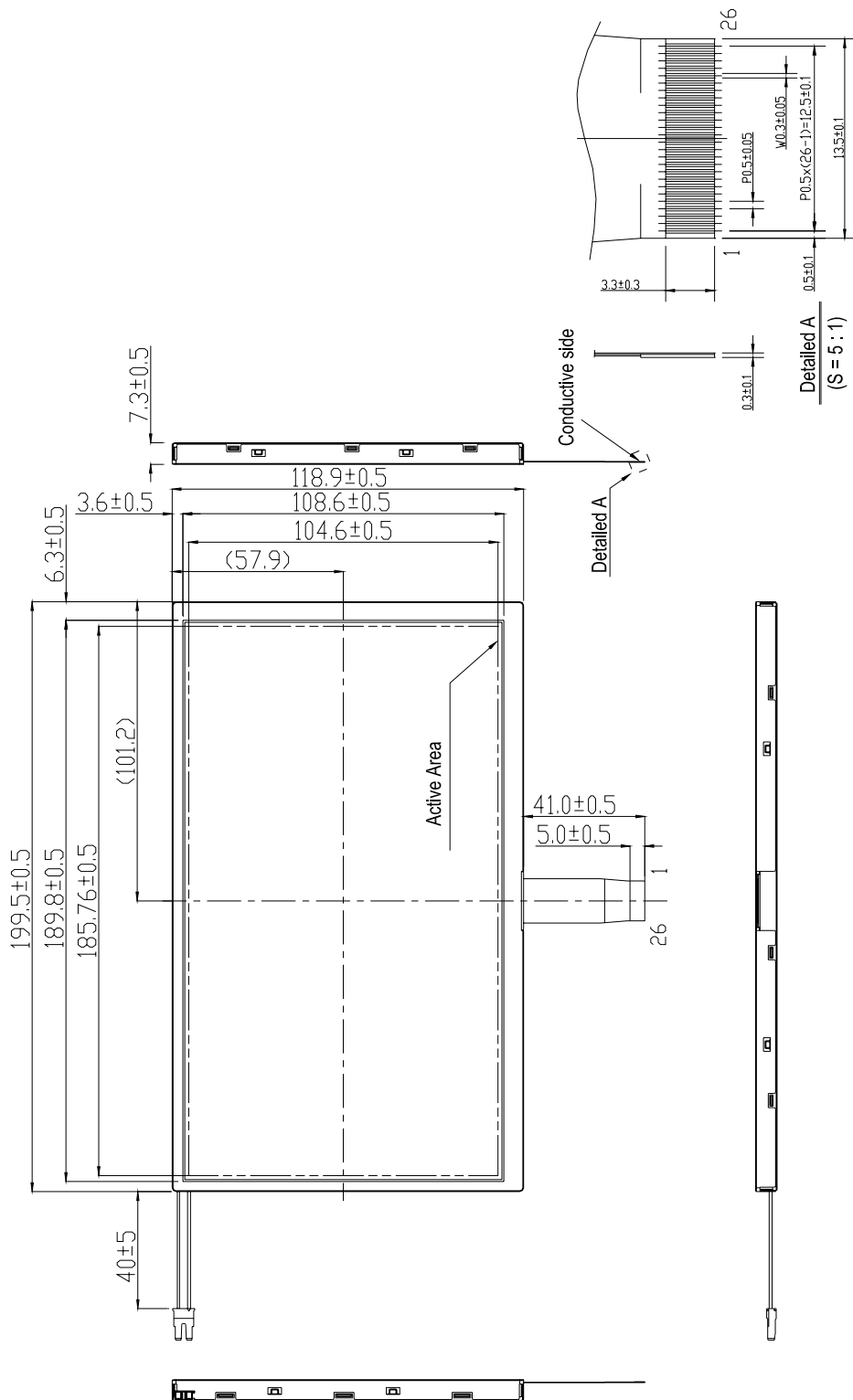

Preliminary

11. Designation Of Lot Mark

11-1. Lot Mark

a) Lot Mark

A	B	C	D	E	F	G	H	I	J	K	L
---	---	---	---	---	---	---	---	---	---	---	---

A : YEAR

B,C : MONTH

D : WEEK

E,F : PRODUCTION MANAGEMENT

G,H,I,J,K : SERIAL NO.

Note

1. YEAR

Year	2003	2004	2005	2006	2007	2008	2009	2010	2011	2012
Mark	3	4	5	6	7	8	9	0	1	2

2. MONTH

Month	Jan	Fed	Mar	Apr	May	Jun	Jul	Aug	Sep	Oct	Nov	Dec
Mark	01	02	03	04	05	06	07	08	09	10	11	12

3. WEEK

Week	1st~7th	8th~14th	15th~21st	22nd~28th	29th~31st
Mark	1	2	3	4	5

4. SERIAL NO.

Year	1~999999	1000000~
Mark	000001~999999	A00000~A99999,,Z99999

b) Location of Lot Mark

Serial NO. is printed on the label. The label is attached to the backside of the LCD module.
 This is subject to change without prior notice.

Preliminary

12. Packing Form

12.1 Inner package

- (1) Quantity : 40pcs/ 1Box
- (2) Size : (L)510x(W)310x(H)269 (unit :mm)

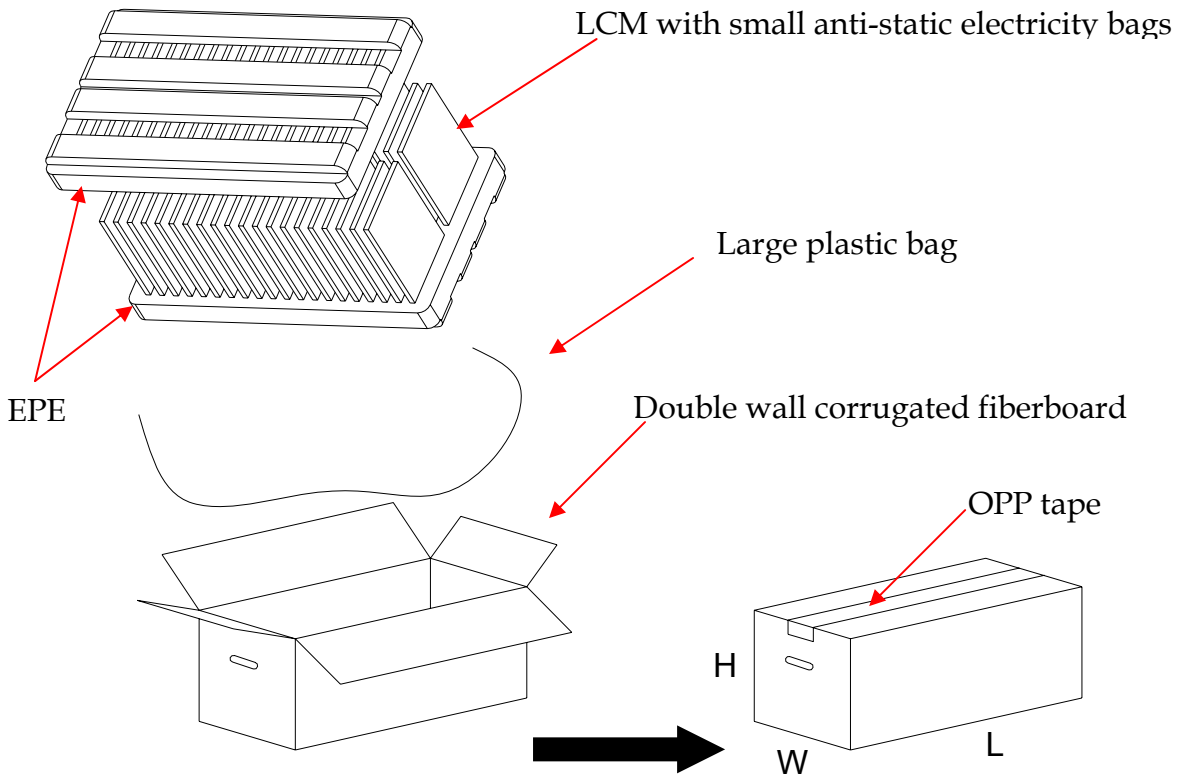

12.2 Outer package

- (1) Quantity : 720pcs/ 1Box
- (2) Size : (L)1100x(W)1000x(H)950 (unit :mm)

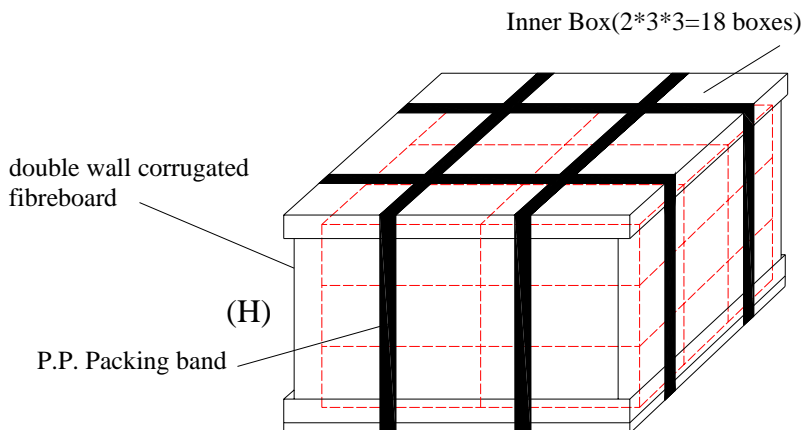

Preliminary

13. PRECAUTIONS

Please pay attention to the following when you use this TFT LCD module.

13-1. MOUNTING PRECAUTIONS

- (1) You must mount a module using arranged in four comers or four sides.
- (2) You should consider the mounting structure so that uneven force (ex. Twisted stress) is not applied to the module.
And the case on which a module is mounted should have sufficient strength so that external force is not transmitted directly to the module.
- (3) Please attach a transparent protective plate to the surface in order to protect the polarizer. Transparent protective plate should have sufficient strength in order to the resist external force.
- (4) You should adopt radiation structure to satisfy the temperature specification.
- (5) Acetic acid type and chlorine type materials for the cover case are not describe because the former generates corrosive gas of attacking the polarizer at high temperature and the latter causes circuit break by electro-chemical reaction.
- (6) Do not touch, push or rub the exposed polarizers with glass, tweezers or anything harder than HB pencil lead. And please do not rub with dust clothes with chemical treatment. Do not touch the surface of polarizer for bare hand or greasy cloth. (Some cosmetics are determined to the polarizer)
- (7) When the surface becomes dusty, please wipe gently with adsorbent cotton or other soft materials like chamois soaks with petroleum benzene. Normal-hexane is recommended for cleaning the adhesives used to attach front / rear polarizers. Do not use acetone, toluene and alcohol because they cause chemical damage to the polarizer.
- (8) Wipe off saliva or water drops as soon as possible. Their long time contact with polarizer causes deformations and color fading.
- (9) Do not open the case because inside circuits do not have sufficient strength.

13-2. OPERATING PRECAUTIONS

- (1) The spike noise causes the mis-operation of circuits. It should be lower than following voltage : $V=\pm 200\text{mV}$ (Over and under shoot voltage)
- (2) Response time depends on the temperature. (In lower temperature, it becomes longer.)
- (3) Brightness depends on the temperature. (In lower temperature, it becomes lower)
And in lower temperature, response time (required time that brightness is stable after turned on) becomes longer.
- (4) Be careful for condensation at sudden temperature change. Condensation makes damage to polarizer or electrical contacted parts. And after fading condensation, smear or spot will occur.
- (5) When fixed patterns are displayed for a long time, remnant image is likely to occur.
- (6) Module has high frequency circuits. Sufficient suppression to the electromagnetic interference shall be done by system manufacturers. Grounding and shielding methods may be important to minimized the interference.

13-3 ELECTROSTATIC DISCHARGE CONTROL

Since a module is composed of electronic circuits, it is not strong to electrostatic discharge. Make certain that treatment persons are connected to ground through wrist band etc. And don't touch interface pin directly.

13-4 PRECAUTIONS FOR STRONG LIGHT EXPOSURE

Strong light exposure causes degradation of polarizer and color filter.

13-5 STORAGE

When storing modules as spares for a long time, the following precautions are necessary.

Preliminary

- (1) Store them in a dark place. Do not expose the module to sunlight or fluorescent light. Keep the temperature between 5°C and 35°C at normal humidity.
- (2) The polarizer surface should not come in contact with any other object. It is recommended that they be stored in the container in which they were shipped.

13-6 HANDLING PRECAUTIONS FOR PROTECTION FILM

- (1) When the protection film is peeled off, static electricity is generated between the film and polarizer. This should be peeled off slowly and carefully by people who are electrically grounded and with well ion-blown equipment or in such a condition, etc.
- (2) The protection film is attached to the polarizer with a small amount of glue. Is apt to remain on the polarizer.
Please carefully peel off the protection film without rubbing it against the polarizer.
- (3) When the module with protection film attached is stored for a long time, sometimes there remains a very small amount of glue still on the polarizer after the protection film is peeled off.
- (4) You can remove the glue easily. When the glue remains on the polarizer surface or its vestige is recognized, please wipe them off with absorbent cotton waste or other soft material like chamois soaked with normal-hexane.